

## Waste To Energy Solution

### For Briquetting Plant-Jumbo-90

<b>Party Name</b>	<b>Date: 13/12/2021</b>
<b>Mr. Neeraj Kadam</b> City: Parbhani Pin Code: State: (Maharashtra) India Email: krushinidhi123@gmail.com, kadam_n_s@yahoo.co.in Tel. No.: Contact No.: +919890796939 Contact Person: Mr. Neeraj Kadam	Quotation No.: JK90/Q31462/21/22
	Enquiry Reference: Indiamart
	<b>Jay Khodiyar Machine Tools</b>
	City: Rajkot (Gujarat) India Email: info@jaykhodiyar.com Tel No. +91-281-2388115, 2367512, 2367594
	Sales Executive: Mitesh Savaliya Sales Person No.: +919586285858 Email: mitesh.savaliya@jaykhodiyar.com

Dear, **Mr. Neeraj Kadam**

Thank you very much for your precious time and sending us your important inquiry for **Briquetting Plant-Jumbo-90**. We would be more than happy to help you further with this project. We assist you in making right choice of place and Project for the plant.

Every year millions tons of waste generated. We provide solution for all this Biomass, agricultural waste, timber waste, wood waste, veneer waste, forestry waste, municipal solid waste by converting in to fuel briquette.

Jay Khodiyar is as leading manufacturer & exporter of wood chipper, sawdust machine, rotary dryer, biomass dryer, flash dryer, briquetting plant, municipal solid waste dryer, briquette machine since 1994.

We have successfully installed Briquetting Machine, Wood Chipper, Drying System in more than 5500+ projects in 75+ countries. Having gained expertise with time, we have unrivalled know-how in our field and can always find the best solution to our customers' needs.

Our main export regions are U.S.A., South America, U.K., U.A.E., Canada, European Countries, Australia, Malaysia, Vietnam, African Countries etc. We are CE Certified Company and Patent and Design Registered, ISO certified and we follow the European Standards in our products.

we are providing following options considering your business requirement.

1. Briquetting Plant 65mm
2. Briquetting Plant 75mm
3. **Briquetting Plant-Jumbo-90**
4. Wood Chipper Machine Model 2000 to 10000 Kg /Hr
5. Biomass Dryer System Model 2000 To 3000 Kg/Hr
6. Rotary Dryer Model 2000 To 5000 Kg/Hr

**Jay Khodiyar Machine Tools**

Samrat Industrial Area, Street No.2, Opp. Kaneriya Oil Industries, Gondal Road, Rajkot-360004 (Gujarat) India.

**Tel.:-** +91-281-2373344, 2367512, 2367594, 2388115, **Helpline:** +91 7600000015, 16, 17, 18, 19

**Email:** info@jaykhodiyar.com | **Web:** www.jaykhodiyar.com | **Whatsapp:** +91 7600000016, 9825325361



This is system generated Approved Document.

1 Plant Land Specification		
1	Total Land Required	2000 to 2500 Sq. Mt (Approx.)
2	Machine Room (Shed)	6Mt. Width x 22.86Mt. Length x 4.87Mt. Height (For One Machine) 9.14Mt. Width x 22.86Mt. Length x 4.87Mt. Height (For Two Machine)
3	Shed For Raw Material	6Mt. Width x 15.24Mt. Length x 4.87Mt. Height (For One Machine) 9.14Mt. Width x 15.24Mt. Length x 4.87Mt. Height (For Two Machine)
4	Foundation Required	Yes / Drawing will be provided by Jay Khodiyar

## 2. Plant Layout View Specification

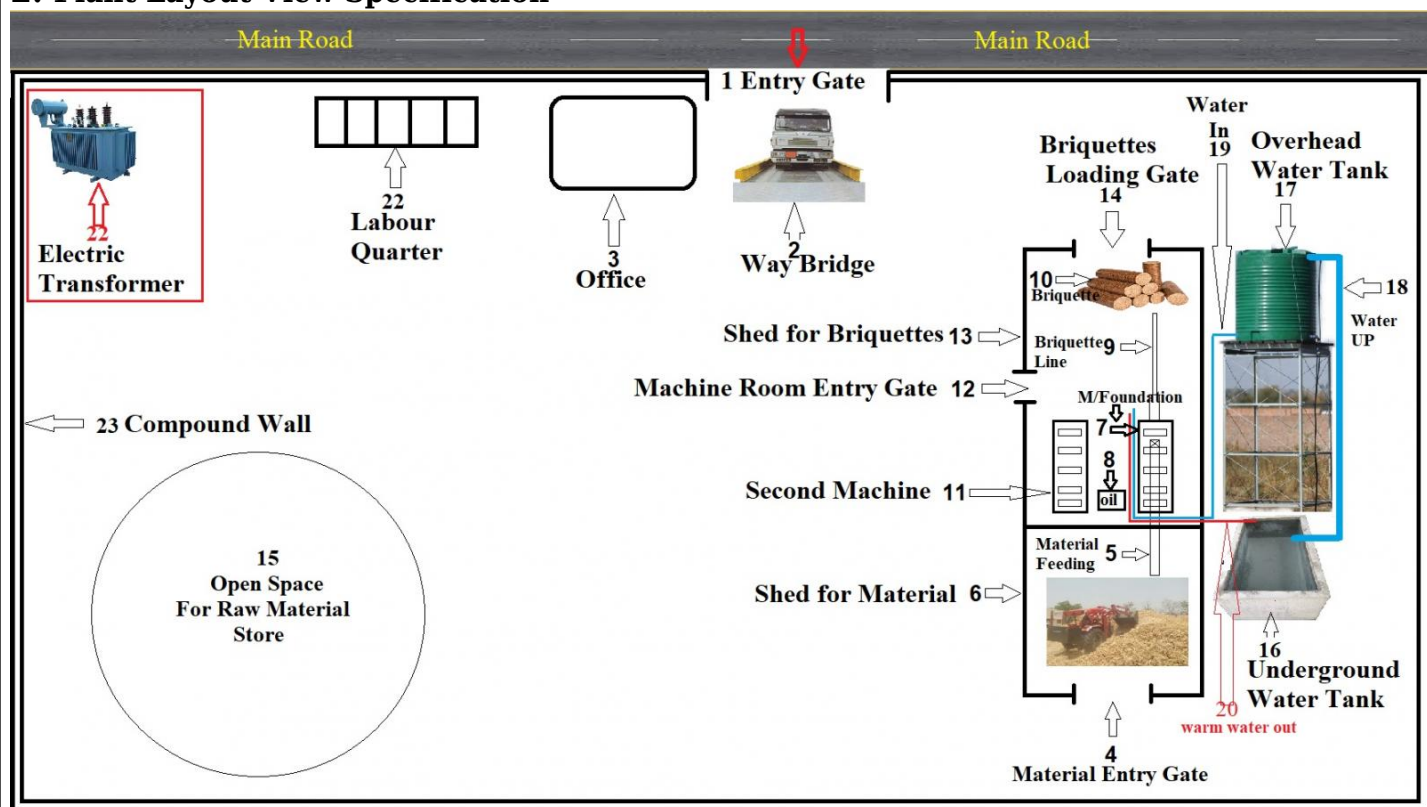

## Electrical Data of Briquetting Plant-Jumbo-90

No	Particulars	Nos	HP	RPM	Required Load	Full Load AMP. (Approx.)
1	Main Motor	1	75HP	1500	60 HP	60-75 Amp.
2	Funnel Motor	1	10HP	1500	7 HP	8-10 Amp.
3	Screw Conveyor Motor	1	3HP	1500	3 HP	3 Amp.
4	Lubrication System Motor	1	3HP	1500	3 HP	3 Amp.
5	Total Power Required	4	91HP /67.85Kw		73 HP	74 - 91 Amp.

All supply 415 Volt +-10% in working. (We Provide Electric Motors Siemens and ABB Company Only)

**Jay Khodiyar Machine Tools**  
 Samrat Industrial Area, Street No.2, Opp. Kaneriya Oil Industries, Gondal Road, Rajkot-360004 (Gujarat) India.

Tel.:- +91-281-2373344, 2367512, 2367594, 2388115, Helpline: +91 7600000015, 16, 17, 18, 19

Email: info@jaykhodiyar.com | Web: www.jaykhodiyar.com | Whatsapp: +91 7600000016, 9825325361



This is system generated Approved Document.

## General Description of Briquetting Plant-Jumbo-90

- If Raw material bigger than 20mm Crusher or chipper Grinder would be required
- If you have wood logs and wood waste then you can make sawdust from our wood powder making machine.
- If raw material has higher moisture than 12% then it should be reduced by sun drying or using drying system.
- From the storage silo or screw conveyor the biomass is transferred to a feeder and then briquetted in a cylindrical shape.
- Briquettes are formed in shape of log and it is automatically pushed through cooling line to the storage point

### 1 For Example Raw Material Details

1	Groundnut Shell / Custer Shell.	Sawdust / Wood Powder / Wood Waste
2	Coffee Husk/Mustard Husk, Straw	Corn Cobs/Soyabean Straw/Soyabean Husk/Rice Husk
3	Sugarcane Bagasse / Rice Straw	Cotton stalk/ Cotton Shell / Palm waste
4	Agricultural waste, timber waste, wood waste, veneer waste, forestry waste, You can make briquette from any type of waste	

### 2 Production Capacity For Example

1	Groundnut Shell	1500 to 2500 Kg/Hr (Approx.)
2	Sawdust / Wood Powder	1500 to 2000 Kg/Hr (Approx.)
3	Soyabean Straw / Mustard Straw	1200 to 1500 Kg/Hr (Approx.)
4	Sugarcane Bagasse	1200 to 1500 Kg/Hr (Approx.)
5	Any Other Raw Material	1200 to 1500 Kg/Hr (Approx.)

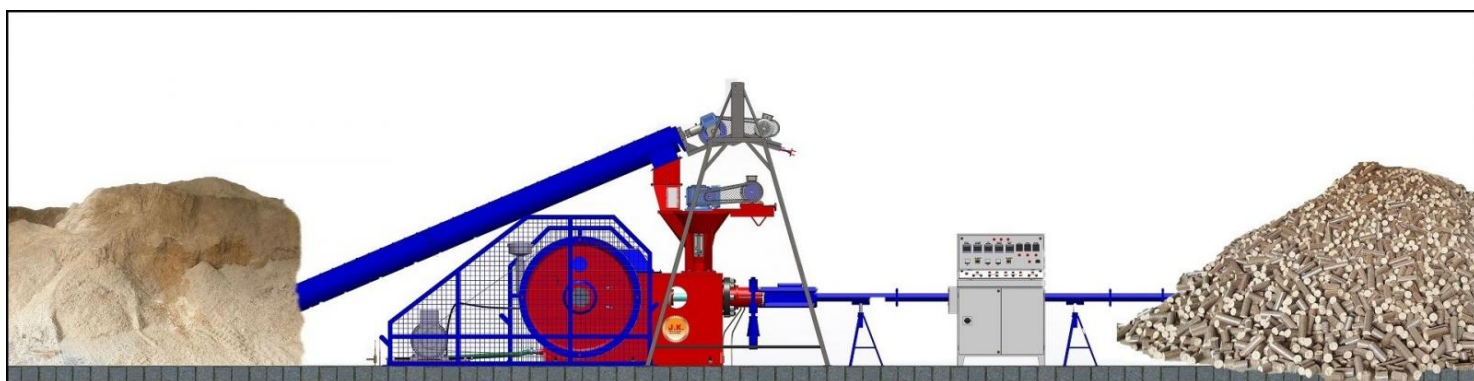

**Jay Khodiyar Machine Tools**

Samrat Industrial Area, Street No.2, Opp. Kaneriya Oil Industries, Gondal Road, Rajkot-360004 (Gujarat) India.

**Tel.:-** +91-281-2373344, 2367512, 2367594, 2388115, **Helpline:** +91 7600000015, 16, 17, 18, 19

**Email:** info@jaykhodiyar.com | **Web:** www.jaykhodiyar.com | **Whatsapp:** +91 7600000016, 9825325361



This is system generated Approved Document.

## Technical Specification of Briquetting Plant-Jumbo-90

### 1 Raw Material And Finished Product Details

1	Feeding Raw Material Size	Up to 15 mm max, if size is bigger than 20 mm, then it need to be chipper grinded before feeding the press machine
2	Moisture Content of Raw Material	8% to 12 % If Moisture content in raw material is more than 15 %, Drying system would be required
3	Briquette Diameter /Length /Shape	<b>90mm /Shape:</b> Cylindrical/ <b>Length:</b> 50mm to 350mm (if you required can be adjusted with cutter)
4	<b>Production Capacity:- 1200 to 2000 Kg/Hr 10% ±</b> (* The production capacity depends on the density of the raw material and Moisture.)	

### 2 Electricity Power

1	Practical used Amp. Load: 74-91 Amp.(Approx)	Power consumption: Up to 40 Unit / Hr (Approx.)
---	--	---

### 3 Manpower Specification

1	Trained Skilled Operator - 1	Unskilled Workers - 2 Per Shift	Tractor Loader Operator - 1 Per Shift
---	------------------------------	---------------------------------	---------------------------------------

### 4 Specifications of press machine

1	Made From (MOC): Ms & Other Steel	Press Machine RPM: 230 to 240 Rpm
2	<b>Total Weight of complete plant:- 8200kg (Approx.)</b> Can be carried in single truck load or small Container	

### Technology & Features

High reliability and long operational lifetime.	Extremely low maintenance and operating costs
High structural strength	Easy maintenance
Auto Reverse and Forward during over feeding	You can operating 24 x 7 without stop

### Working Parameters

- Control Panel will be used to operate the Briquetting Plant-Jumbo-90
- The machine can run in both Auto & Manual Override Options
- In case of over feeding, Briquetting Plant-Jumbo-90 funnel screw will Reverse Automatically to safeguard the Briquetting Plant-Jumbo-90 from any damage
- Briquetting Plant-Jumbo-90 can be stopped using Emergency Switches used at the In-feed Conveyor & Panel to stop the machine in case of emergency.



Samrat Industrial Area, Street No.2, Opp. Kaneriya Oil Industries, Gondal Road, Rajkot-360004 (Gujarat) India.  
**Tel.:-** +91-281-2373344, 2367512, 2367594, 2388115, **Helpline:** +91 7600000015, 16, 17, 18, 19  
**Email:** info@jaykhodiyar.com | **Web:** www.jaykhodiyar.com | **Whatsapp:** +91 7600000016, 9825325361



This is system generated Approved Document.

## Scope of Jay Khodiyar Machine Tools

- **Main Unit Briquetting Plant-Jumbo-90: Includes the Below**
- Electric motor of **75 HP** (1500 RPM) with Motor Pulley to drive machine fly wheels
- Main Motor Railling
- Electric motor **10 HP** (1500 RPM) with Funnel SNU-5 Gearbox With Accessory
- Electric Motor **3 HP** (1500 RPM) with for Lubrication Oil System & Pressure meter.
- Fly Wheel With Endless Nylon Flat Belt
- Die Holder (Main Die Head)
- Half Round (Ring) Clamp. (For Die Holder)
- Manual Jack with Square Clamp Set. (For Die Holder)
- Briquette Gate (Socket) with Briquette Lines (Length 24ft)
- Electrical Control Panel Board for Operating Systems.
- Electrical Sensors (Die Holder, Piston (Machine), Oil System) and Oil Pressure Indicator
- Machine Foundation Stud For Machine & Main Motor
- Auxiliary Spares like Ram, Taper Die, Collets, Split Die & Oil Seal (As Mentioned Below)
- Lifting stand with Chain Pulley (Wt. 2 Mt/Tn Cap.)
- Spanners & Tools Kit

## Material Handling Screw Conveyor

- Screw conveyor 20 feet long with 5 mm worm thickness.
- Electric motor **3HP (1500RPM)** with Reduction gearbox and Pulley & V-belt for speed control.

## Note:

- We use Gearbox **Elecon** or **Bonfiglioli** Company only
- We use Electrical Panel Board Parts **Siemens** and **ABB Company Only**
- We use Electric Motors **Siemens** and **ABB Company Only**

## Spare Parts With Briquetting Plant-Jumbo-90

No	Particulars	In Machine (Qty.)	Extra Parts (Qty.)
1	Ram (Punch)	1	1
2	Taper Die	1	1
3	Collette Ring	1	4
4	Split Die	1	1
5	Screw Waram	1	1
6	Feeder Box	1	1
7	Oil Seal (For Crank, Piston, Ram, Feeder box)	1	2

## Note:

- We reserve the right to change any specification for the Jay Khodiyar Briquetting Plant-Jumbo-90 without any intimation

**Jay Khodiyar Machine Tools®**

Samrat Industrial Area, Street No.2, Opp. Kaneriya Oil Industries, Gondal Road, Rajkot-360004 (Gujarat) India.

**Tel.:-** +91-281-2373344, 2367512, 2367594, 2388115, **Helpline:** +91 7600000015, 16, 17, 18, 19

**Email:** info@jaykhodiyar.com | **Web:** www.jaykhodiyar.com | **Whatsapp:** +91 7600000016, 9825325361



## Prerequisite For Installing Briquetting Plant-Jumbo-90 From Buyer's End.

Client needs to arrange or complete following process prior to installing machine.

- All civil work like foundation and construction of the shed to be completed.
- Client shall arrange 3 phase electricity connection of **91 HP (67.85 KW)**
- Electric connection at machine Room from the Electric panel to Main Motor, 2 pieces of 10 meters (33 feet) Aluminum cable 50mm, 4 core or Copper Cable you will require 35mm 4 core.
- From Electric panel to Funnel Motor 4mm Copper Cable 15 meters, and for Conveyor Motor & Oil System Motor 2.5 mm Copper Cable 30 meters are required.
- Lubricating oil -1 barrel 320 grade industrial Gear oil
- Skilled and unskilled workers at the time of erection & commissioning
- If require any extra changes or require any material at time of installation that material you have to arrange and provide.

## Important Notes For Briquetting Plant-Jumbo-90

- We do not take any responsibility for any damage happen when Briquetting Plant-Jumbo-90 installed in open ground.
- Shed is necessary required on briquetting machine so machine must install under the shed and if equipments installed in open ground then build shed instantly.

## Briquetting Plant-Jumbo-90 Elevation

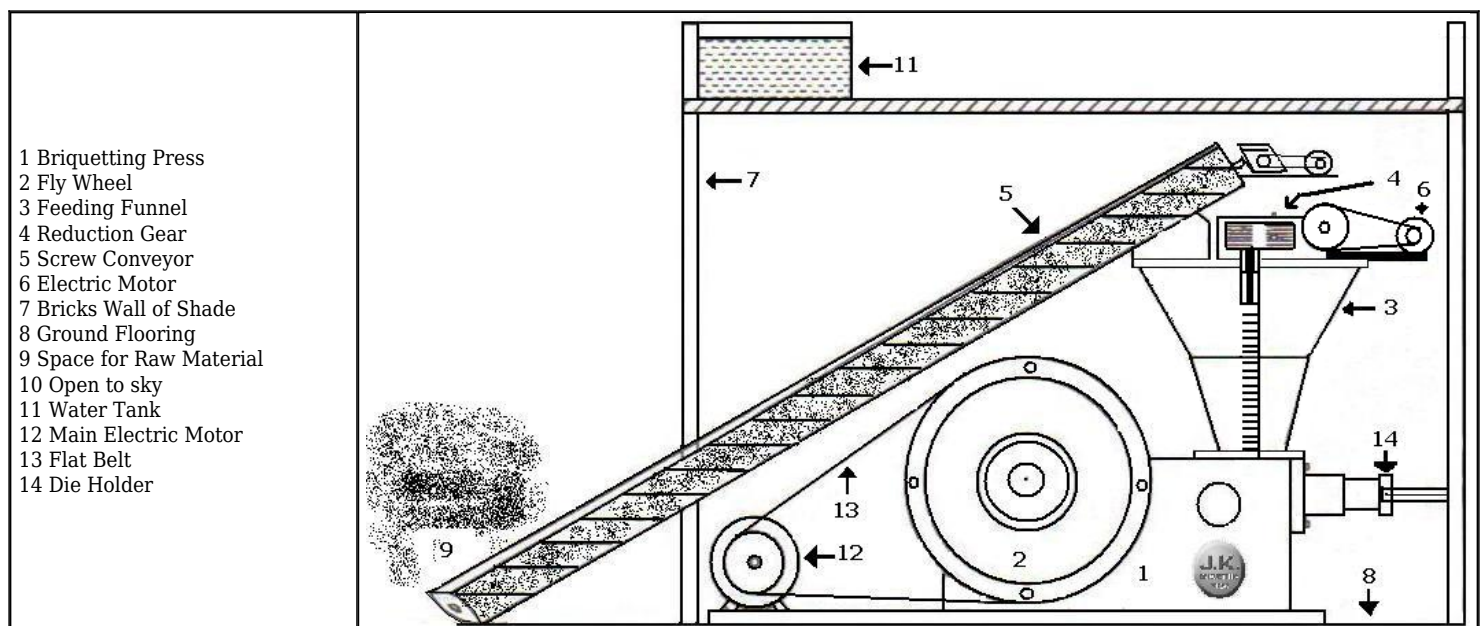

# Jay Khodiyar Machine Tools®

Samrat Industrial Area, Street No.2, Opp. Kaneriya Oil Industries, Gondal Road, Rajkot-360004 (Gujarat) India.

**Tel.:-** +91-281-2373344, 2367512, 2367594, 2388115, **Helpline:** +91 7600000015, 16, 17, 18, 19

**Email:** info@jaykhodiyar.com | **Web:** www.jaykhodiyar.com | **Whatsapp:** +91 7600000016, 9825325361



This is system generated Approved Document.

## Commercial Terms & Conditions for Briquetting Plant-Jumbo-90

Jay Khodiyar Mechanical briquetting system designed to make briquettes without using any binder from any type of agricultural waste, forestry waste and wood waste with acceptable moisture in raw material should not be more than 12%. and size should not be more than 20mm.

Sr.No.	Description	Rate	Qty.	Amount
1	Briquetting Plant-Jumbo-90	18,05,000.00	1	18,05,000.00
2	Erection & Commissioning Charges	Included	1	Included
<b>(In Words: Eighteen Lakhs Five Thousand INR Only)</b>			<b>TOTAL INR 18,05,000.00</b>	

### 1. **Payment Milestone:**

- 40% of the ordered value in advance along with your confirm order
- Balance payment within 30days of Booking.

### 2. **Our Bank Details:**

- Beneficiary Account Name: Jay Khodiyar Machine Tools**
- HDFC BANK LTD., Swaminarayan Chowk, Rajkot (GUJ) India. Our Account No. 50200041648684 (IFSC CODE: HDFC0009368)**

### 3. **Taxes:**

- Taxes will be charged extra on actual at the time of delivery.
- GST of 18% would be applicable extra.If any changes in the tax at the time of delivery will be paid by the buyer.

**Note:** Client should submit GST number before equipment delivery.

- Transportation :-** Our offer is ex-factory Rajkot (Gujarat). Client shall arrange Freight, transportation, unloading, Crane charges and transit insurance Etc. Jay Khodiyar Machine tools is not responsible for any damages during transportation.
- Delivery schedule :** Within 30/40 days on receipt of order confirmation and advance payment.
- Payment Mode:** All payments need to be made in favor of **Jay Khodiyar Machine Tools** Payable at Rajkot and payment should be in form of **RTGS/NEFT/Cheque/Draft**. We are not responsible for the accounting of any Cash Transaction.
- Force majeure :** As mentioned below in General Terms & Conditions.
- Note:** This price confide for standard equipment only. Jay Khodiyar Machine Tools have all the right to change price policy in case of any material rate change or any customization. and if delivery not taken within **45days** of booking.
- Validity:** our offer is valid for a period of **30 days** there after it is subject to our confirmation.

For, Jay Khodiyar Machine Tools

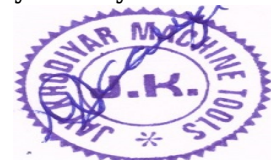

Authorised Person

# Jay Khodiyar Machine Tools®

Samrat Industrial Area, Street No.2, Opp. Kaneriya Oil Industries, Gondal Road, Rajkot-360004 (Gujarat) India.

**Tel.:-** +91-281-2373344, 2367512, 2367594, 2388115, **Helpline:** +91 7600000015, 16, 17, 18, 19

**Email:** info@jaykhodiyar.com | **Web:** www.jaykhodiyar.com | **Whatsapp:** +91 7600000016, 9825325361



## General Terms & Conditions For Briquetting Plant-Jumbo-90

1. **Prices:** Quoted Price is ex-factory, Jay Khodiyar Machine Tools Rajkot, (Gujarat)
2. **Packing & Forwarding:** Extra on actual (if required)
3. **Taxes & Duties:** GST and Other statutory policy as applicable at the time of delivery will be borne by the buyer.
4. **Insurance:** Insurance to be covered & borne by buyers.
5. **Delivery:** The delivery period will be effected from the date of receipt of your technically and commercially cleared order with 100% advance payment, the delivery period quoted is good faith and is subject to force & Major Clause.
6. **Erection Commissioning & Services:-** Clients Scope of Work & Responsibility. The Activities to be carried out by us are based on following pre-requisites to be completed before hand, simultaneously by customer
  - To arrange for any kind of State Government and Central Government Clearance as and when required for consignment received from Jay Khodiyar Machine Tools
  - The Erection Commissioning & Services will be done by our technicians. technicians team will be sent from our firm to handle the process. Facilities at site, Lodging, boarding & Air Fares to be provided by consignee.
  - To arrange all Civil Works and earth grid including equipment foundation (as per the prescribed format)
  - To arrange as per prescribed Electrical supply and water supply during supervision & commissioning
  - To arrange following equipment: Gas cutting, Welding set, Chain pulley, Crane and oil supply
  - If necessary, we will provide training facility to buyer's operator at buyer's work site for a period of 5 to 7 days at buyer's Cost
  - **Note:** This form of training is beneficial for the organizations as well as the technicians who operate it, since they will be provided with in-depth knowledge of the equipment, so that operation performed maximum production against minimum maintenance.
7. **Inspection:** If inspection is required prior to dispatch, various inspection of various equipment can be availed at our factory at buyers cost, the same need to be intimated 4 days prior to inspection. All materials dispatched shall be however tested under no load condition
8. **Termination Policy:**
  - If buyer fails to fulfill any of the payment conditions set forth in the Contract Seller may suspend. After purchase order of the equipments if buyers want to cancel the order then cancellation is as per our quotation and sales contract policy.
  - Seller under the contract on the agreed terms of payment, seller require payment as per the delivery schedule or after giving the delivery notice if buyer fails to do that seller has right to terminate the contract or buyer has to accept our current rates at time of delivery.
  - If buyer becomes insolvent, makes an assignment for the benefits of its creditors, has a receiver or trustee appointed for the benefit of its creditors, or files for protection from creditors under any bankruptcy or insolvency laws, seller shall be entitled to terminate the contract.
  - There is no legal laws applied in case of buyer fail to make payments as per delivery schedule or order cancellation or buyer failed to run equipments. Once the equipments dispatch from our factory and some of reason buyer fail to run machine in any type of case we do not take or return equipments back.

**Jay Khodiyar Machine Tools**

Samrat Industrial Area, Street No.2, Opp. Kaneriya Oil Industries, Gondal Road, Rajkot-360004 (Gujarat) India.

**Tel.:-** +91-281-2373344, 2367512, 2367594, 2388115, **Helpline:** +91 7600000015, 16, 17, 18, 19

**Email:** info@jaykhodiyar.com | **Web:** www.jaykhodiyar.com | **Whatsapp:** +91 7600000016, 9825325361



## Schedule of Termination

No. of days after after booking date	Order Termination Charges
within 10 days	30%
between 11 to 20 days	70%
between 21 to 30 days	<b>Not Refundable</b>

9. **Force & Majeure:** We shall be under not liability by causes beyond our control such as war, strikes, lockouts, fires, accidents, epidemics, failure of electric supply, shortage of materials or labour or order of government or other authority or any Natural calamity, means in any unavoidable circumstances we are not liable.
10. **Warranty:** Warranty of Machine is for One Year (12 months) from the date of Sale. Company warrantees the equipment under normal & recommended operation. The damages during transit, bad storage, misuse handling of equipment at customer's site is also not warranted
- We do not take any performance guarantee or any responsibility for any damages happen when machine installed in open ground.
  - Warranty is only valid if Genuine Jay Khodiyar spare parts are used to run the plant. Warranty for any of the electric or transmission and electronic parts items such Motors, Panel and Gearboxs which are in the machinery would be as per the Norms of the respective suppliers Company only.
  - The replacement / repair work done to any of the equipment during tenure of warranty will not increase the warranty of product.
  - Jay Khodiyar will be free from any type of product liability and guarantee obligations if any modification done to the Plant Machinery without written consent of Company in any manner.
  - If any manufacturing fault is noticed during the warranty period, then company will repair the defected part free of cost, but client must pay the transportation charges of such part. Client should inform within 2 working days from the time of the noticeable defect.
  - During the break down period seller bears no responsibility for any loss of production, revenue etc.
  - We do not give any type of guarantee or warranty on to the any inner side or outer side wear and tear spare parts in machine.
  - Negligence /Accident /Mishandling / Failure or Damage Caused by Foreign Material in Equipments
  - **Safety Policy:** All personnel working on a plant machine must wear all type of safety gears such as face mask, safety glasses, helmet, gloves, proper uniform and shoes etc. seller will not be liable if any injury takes place at the working site due to neglecting the safety standard operating procedures.
11. **Exclusion:** Civil Engineering works of any nature, water tank, water pipe line, electric cabling to control panel, shifting of equipment from your store to erection site and any other items not specifically covered by our offer.
12. **All arbitration subject to Rajkot (Gujarat) jurisdiction only.**

For, Jay Khodiyar Machine Tools



Authorised Person

**Jay Khodiyar Machine Tools®**

Samrat Industrial Area, Street No.2, Opp. Kaneriya Oil Industries, Gondal Road, Rajkot-360004 (Gujarat) India.

**Tel.:-** +91-281-2373344, 2367512, 2367594, 2388115, **Helpline:** +91 7600000015, 16, 17, 18, 19

**Email:** info@jaykhodiyar.com | **Web:** www.jaykhodiyar.com | **Whatsapp:** +91 7600000016, 9825325361



This is system generated Approved Document.